

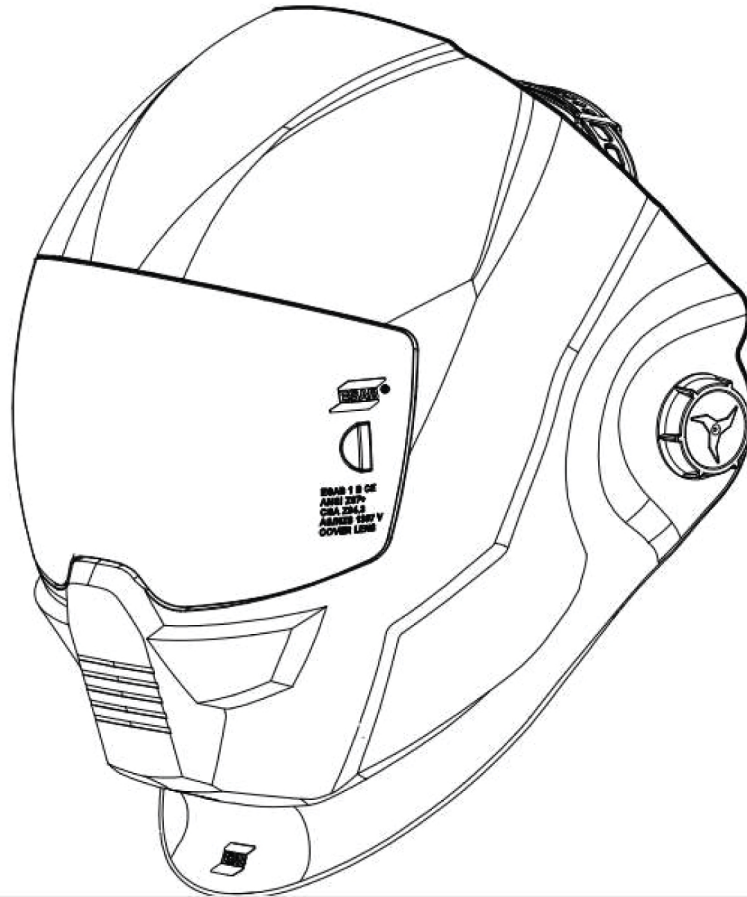

Sentinel A-60



Auto Darkening Welding Helmet

Instruction manual and Spare parts list

PLEASE READ AND UNDERSTAND ALL INSTRUCTION BEFORE USE. RETAIN THIS MANUAL FOR FUTURE REFERENCE.

Complete User Manual at:

Manual Number: 0-5659
Revision Date: 2025-03-14
Revision Number: A
Language: English UK





EU DECLARATION OF CONFORMITY

According to the Council Directive (EU) 2016/425 entering into force 9 March 2016
This declaration of conformity is issued under the sole responsibility of the manufacturer.

Type of equipment

Welding Helmet

Type designation

Sentinel A60 0700600860

Sentinel A60 Air 0700600861

Brand name or trademark

ESAB

Manufacturer or his authorized representative established within the EEA**Name, address, and telephone No:**

ESAB AB

Lindholmsallén 9, Box 8004

402 77 Gothenburg, Sweden

Phone: +46 (0) 31 50 90 00

The following harmonized standard in force within the EEA has been used in the design:

EN 166:2001 Personal eye protection - Specifications

EN 175:1997 Personal protection. Equipment for eye and face protection during welding and allied processes

EN 379:2009 Personal eye protection – Automatic welding filters

ISO 16321-2:2021 – Eye and face protection for occupational use – Part 2: Additional requirements for protectors used during welding and related techniques

EC Type Examination Certificate and Test Certificates issued by:

ECS GmbH – European Certification Service

Hüttfeldstrasse 50

73430 Aalen, Germany

Notified body number 1883

performed and issued the EU type-examination certificates C3462.2ESAB, C3463.1ESAB, C3464.1ESAB, C3492.1ESAB, C3493.1ESAB, C3506.1ESAB, C3507.1ESAB, C3508.1ESAB, C3509.1ESAB, C3510.1ESAB

By signing this document, the undersigned declares as manufacturer, or the manufacturer's authorized representative, that the equipment in question complies with the safety requirements stated above.

Date

Signature

Position

2022-11-15

ESAB Global R&D Standards and
Regulatory Expert

CE 2022

TABLE OF CONTENTS

1	SAFETY	4
1.1	Meaning of symbols	4
1.2	Safety instructions for auto-darkening welding helmet and filter	4
1.3	Safety precautions	5
1.4	California proposition 65 warning	9
2	INTRODUCTION	10
2.1	Certification and control labels	10
3	TECHNICAL DATA	12
3.1	Shade guide	12
4	INSTALLATION	14
4.1	Installing the battery	14
4.2	Installing magnifying lens	14
4.3	Adjusting the fit of the helmet	15
5	OPERATION	16
5.1	Activating the LED display	16
5.2	Battery indicator	16
5.3	Activating grind mode	16
5.4	Setting shade number	17
5.5	Setting sensitivity	17
5.6	Setting delay	17
5.7	Saving parameters to memory settings	18
5.8	Activating lock shade mode	18
6	MAINTENANCE	19
6.1	Replacing the front cover lens	19
6.2	Replacing the inside cover lens	19
6.3	Replacing the Auto-Darkening-Filter (ADF)	20
6.4	Cleaning the equipment	20
7	TROUBLESHOOTING	21
	SPARE PARTS	22

1 SAFETY



WARNING!

Read and understand this entire manual and your employer's safety practices before installing, operating, or servicing the equipment.

While the information contained in this manual represents the Manufacturer's best judgment, the manufacturer assumes no liability for its use.



WARNING!

- **INGESTION HAZARD:** This product contains a button cell or coin battery.
- **Death** or serious injury can occur if ingested.
- A swallowed button cell or coin battery can cause **Internal Chemical Burns** in as little as **2 hours**.
- **KEEP** new and used batteries **OUT OF REACH OF CHILDREN**.
- **Seek immediate medical attention** if a battery is suspected to be swallowed or inserted inside any part of the body.



1.1 Meaning of symbols

As used throughout this manual: Means Attention! Be Alert!



DANGER!

Means immediate hazards which, if not avoided, will result in immediate, serious personal injury or loss of life.



WARNING!

Means potential hazards which could result in personal injury or loss of life.



CAUTION!

Means hazards which could result in minor personal injury.



WARNING!

Before use, read and understand the instruction manual and follow all labels, employer's safety practices and Safety Data Sheets (SDSs).



1.2 Safety instructions for auto-darkening welding helmet and filter

Before use

The auto-darkening welding helmet comes assembled, but before it can be used, perform the following:

- Adjust the helmet to fit the user properly.
- Check battery surfaces and contacts and clean them if necessary.
- Verify that the battery is in good condition and properly installed.
- Set up for delay time, sensitivity, and shade number for your application.

Usage

- The helmet is not suitable for laser welding.

- Never place the helmet and auto-darkening filter on a hot surface.
- The helmet will not protect against severe impact hazards.
- The helmet will not protect against explosive devices or corrosive liquids.
- Should the helmet not darken upon striking an arc, stop welding immediately and contact ESAB.
- Do not immerse the filter in water.
- The materials which may come into contact with the wearer's skin can cause allergic reactions in some circumstances.
- The filter shall only be used in conjunction with the inner cover lens.

Maintenance

- The helmet should be stored in a cool, dry, and dark place. Remove the battery before long-time storage.
- Protect filter from contact with liquid and dirt.
 - Clean the filter surface regularly by using clean water and a lint-free or microfiber cloth; do not use strong cleaning solutions. Always keep the sensors and solar cells clean using a clean lint-free tissue or microfiber cloth.
 - Regularly replace the cracked/scratched/pitted front cover lens. Avoid setting the helmet down directly on the cover lens to avoid premature damage to the cover lens.
- Never open or tamper with the filter. There are no user-serviceable parts inside.
- Do not make any modifications to either the filter or helmet, unless specified in this manual.
- Only use replacement parts that are specified in this manual.
- Unauthorized modifications and replacement parts will void the warranty and expose the operator to personal injury.
- Do not use any solvents on the filter screen or helmet components.

1.3 Safety precautions



WARNING!

These Safety Precautions are for your protection. They summarise precautionary information from the references listed in Additional Safety Information section. Before performing any installation or operating procedures, be sure to read and follow the safety precautions listed below as well as all other manuals, material safety data sheets, labels, etc. Failure to observe Safety Precautions can result in injury or death.



PROTECT YOURSELF AND OTHERS

Some welding, cutting and gouging processes are noisy and require ear protection. The arc, like the sun, emits ultraviolet (UV) and other radiation and can injure skin and eyes. Hot metal can cause burns. Training in the proper use of the processes and equipment is essential to prevent accidents. Therefore:

1. Wear a welding helmet fitted with a proper shade of filter to protect your face and eyes when welding or watching.
2. Always wear safety glasses with side shields in any work area, even if welding helmets face shields and goggles are also required.
3. Use a face shield fitted with the correct filter and cover plates to protect your eyes, face, neck and ears from sparks and rays of the arc when operating or observing operations. Warn bystanders not to watch the arc and not to expose themselves to the rays of the electric-arc or hot metal.
4. Wear flameproof gauntlet type gloves, heavy long-sleeve shirt, cuff less trousers, high-topped shoes and a welding helmet or cap for protection, to protect against arc rays and hot sparks or hot metal. A flameproof apron may also be desirable as protection against radiated heat and sparks.
5. Hot sparks or metal can lodge in rolled up sleeves, trouser cuffs, or pockets. Sleeves and collars should be kept buttoned and open pockets eliminated from the front of clothing.
6. Protect other personnel from arc rays and hot sparks with a suitable non-flammable partition or curtains.

7. Use goggles over safety glasses when chipping slag or grinding. Chipped slag may be hot and can fly far. Bystanders should also wear goggles over safety glasses.



FIRES AND EXPLOSIONS

Heat from flames and arcs can start fires. Hot slag or sparks can also cause fires and explosions. Therefore:

1. Protect yourself and others from flying sparks and hot metal.
2. Remove all combustible materials well away from the work area or cover the materials with a protective non-flammable covering. Combustible materials include wood, cloth, sawdust, liquid and gas fuels, solvents, paints and coatings paper, etc.
3. Hot sparks or hot metal can fall through cracks or crevices in floors or wall openings and cause a hidden smoldering fire or fires on the floor below. Make certain that such openings are protected from hot sparks and metal.
4. Do not weld, cut or perform other hot work until the work piece has been completely cleaned so that there are no substances on the work piece which might produce flammable or toxic vapors. Do not do hot work on closed containers, they may explode.
5. Have fire extinguishing equipment handy for instant use, such as a garden hose, water pail, sand bucket, or portable fire extinguisher. Be sure you are trained in its use.
6. Do not use equipment beyond its ratings. For example, an overloaded welding cable can overheat and create a fire hazard.
7. After completing operations, inspect the work area to make certain there are no hot sparks or hot metal which could cause a later fire. Use fire watchers when necessary.



ELECTRICAL SHOCK

Contact with live electrical parts and ground can cause severe injury or death. DO NOT use AC welding current in damp areas, if movement is confined, or if there is danger of falling. Therefore:

1. Be sure the power source frame (chassis) is connected to the ground system of the input power.
2. Connect the workpiece to a good electrical ground.
3. Connect the work cable to the workpiece. A poor or missing connection can expose you or others to a fatal shock.
4. Use well-maintained equipment. Replace worn or damaged cables.
5. Keep everything dry, including clothing, work area, cables, torch/electrode holder and power source.
6. Make sure that all parts of your body are insulated from both the work piece and from the ground.
7. Do not stand directly on metal or the earth while working in tight quarters or a damp area; stand on dry boards or an insulating platform and wear rubber-soled shoes.
8. Put on dry, hole-free gloves before turning on the power.
9. Turn off the power before removing your gloves.
10. Refer to ANSI/ASC Standard Z49.1 for specific grounding recommendations. Do not mistake the work lead for a ground cable.



ELECTRIC AND MAGNETIC FIELDS

May be dangerous. Electric current flowing through any conductor causes localized Electric and Magnetic Fields (EMF). Welding and cutting current creates EMF around welding cables and welding machines. Therefore:

1. Welders having pacemakers should consult their physician before welding. EMF may interfere with some pacemakers.
2. Exposure to EMF may have other health effects which are unknown.

3. Welders should use the following procedures to minimise exposure to EMF:
 - a) Route the electrode and work cables together. Secure them with tape when possible.
 - b) Never coil the torch or work cable around your body.
 - c) Do not place your body between the torch and work cables. Route cables on the same side of your body.
 - d) Connect the work cable to the workpiece as close as possible to the area being welded.
 - e) Keep welding power source and cables as far away from your body as possible.



FUMES AND GASES

Fumes and gases, can cause discomfort or harm, particularly in confined spaces. Shielding gases can cause asphyxiation. Therefore:

1. Keep your head out of the fumes. Do not breathe the fumes and gases.
2. Always provide adequate ventilation in the work area by natural or mechanical means. Do not weld, cut or gouge on materials such as galvanized steel, stainless steel, copper, zinc, lead beryllium or cadmium unless positive mechanical ventilation is provided. Do not breathe fumes from these materials.
3. Do not operate near degreasing and spraying operations. The heat or arc can react with chlorinated hydrocarbon vapors to form phosgene, a highly toxic gas and other irritant gases.
4. If you develop momentary eye, nose or throat irritation while operating, this is an indication that ventilation is not adequate. Stop work and take necessary steps to improve ventilation in the work area. Do not continue to operate if physical discomfort persists.
5. Refer to ANSI/ASC Standard Z49.1 for specific ventilation recommendations.
6. **WARNING:** This product when used for welding or cutting, produces fumes or gases which contain chemicals known to the State of California to cause birth defects and in some cases cancer (California Health & Safety Code §25249.5 et seq.)



CYLINDER HANDLING

Cylinders, if mishandled, can rupture and violently release gas. A sudden rupture of cylinder valve or relief device can injure or kill. Therefore:

1. Locate cylinders away from heat, sparks and flames. Never strike an arc on a cylinder.
2. Use the proper gas for the process and use the proper pressure reducing regulator designed to operate from the compressed gas cylinder. Do not use adaptors. Maintain hoses and fittings in good condition. Follow manufacturer's operating instructions for mounting regulator to a compressed gas cylinder.
3. Always secure cylinders in an upright position by chain or strap to suitable hand trucks, undercarriages, benches, wall, post or racks. Never secure cylinders to work tables or fixtures where they may become part of an electrical circuit.
4. When not in use, keep cylinder valves closed. Have valve protection cap in place if regulator is not connected. Secure and move cylinders by using suitable hand trucks.



MOVING PARTS

Moving parts, such as fans, rotors and belts can cause injury. Therefore:

1. Keep all doors, panels, guards and covers closed and securely in place.
2. Stop engine or drive systems before installing or connecting unit.
3. Have only qualified people remove covers for maintenance and troubleshooting as necessary.
4. To prevent accidental starting of equipment during service, disconnect negative (-) battery cable from battery.
5. Keep hands, hair, loose clothing and tools away from moving parts.

6. Reinstall panels or covers and close doors when service is finished and before starting engine.



**WARNING!
FALLING EQUIPMENT CAN INJURE**

- Only use lifting eye to lift unit. Do NOT use running gear, gas cylinders or any other accessories.
- Use equipment of adequate capacity to lift and support unit.
- If using lift forks to move unit, be sure forks are long enough to extend beyond opposite side of unit.
- Keep cables and cords away from moving vehicles when working from an aerial location.



**WARNING!
EQUIPMENT MAINTENANCE**

Faulty or improperly maintained equipment can cause injury or death. Therefore:

1. Always have qualified personnel perform the installation, troubleshooting and maintenance work. Do not perform any electrical work unless you are qualified to perform such work.
2. Before performing any maintenance work inside a power source, disconnect the power source from the incoming electrical power.
3. Maintain cables, earthing wire, connections, power cord and power supply in safe working order. Do not operate any equipment in faulty condition.
4. Do not abuse any equipment or accessories. Keep equipment away from heat sources such as furnaces, wet conditions such as water puddles, oil or grease, corrosive atmospheres and inclement weather.
5. Keep all safety devices and cabinet covers in position and in good repair.
6. Use equipment only for its intended purpose. Do not modify it in any manner.



**WARNING!
WELDING HELMET CRITERIA**

1. The protection according to Z87.1 is only given if it is ensured that the product is assembled according to the manufacturer's instructions.
2. The eye-protectors against high-speed particles worn over standard ophthalmic spectacles may transmit impacts, thus creating a hazard to the wearer.
3. If the impact letter followed by letter "T", you can use it for protection against high-speed particles at extremes of temperature. If the impact letter does not follow by letter "T", you should only use the eye protector for protection against high-speed particles at room temperature.
4. A visual inspection of the complete protector is necessary before each use.
5. This protector is appropriate for the headform 1-M.
6. Protector can affect the recognition of colours and/or signal light detection.
7. Protectors that have been subject to impact shall not be used and shall be discarded and replaced.
8. If the impact level symbols are not equal on both the lens/filter and the frame, then it is the lower level that shall be assigned to the complete protector.
9. The protections corresponding to the code numbers/letter 7, 9, CH are provided by the complete protector only if the respective symbols are equal on both the lens and the frame.
10. Not suitable for driving and road use.



CAUTION!
ADDITIONAL SAFETY INFORMATION

For more information on safe practices for electric arc welding and cutting equipment, ask your supplier for a copy of “Precautions and Safe Practices for Arc Welding, Cutting and Gouging”, Form 52-529.

The following publications are recommended:

- ANSI/ASC Z49.1 - “Safety in Welding and Cutting”
- AWS C5.5 - “Recommended Practices for Gas Tungsten Arc Welding”
- AWS C5.6 - “Recommended Practices for Gas Metal Arc welding”
- AWS SP - “Safe practices” - Reprint, Welding Handbook
- ANSI/AWS F4.1 - “Recommended Safe Practices for Welding and Cutting of Containers That Have Held Hazardous Substances”
- OSHA 29 CFR 1910 - "Safety and health standards"
- CSA W117.2 - "Code for safety in welding and cutting"
- NFPA Standard 51B, “Fire Prevention During Welding, Cutting, and Other Hot Work”
- CGA Standard P-1, “Precautions for Safe Handling of Compressed Gases in Cylinders”
- ANSI Z87.1, "Occupational and Educational Personal Eye and Face Protection Devices"

1.4 California proposition 65 warning



WARNING!

Welding or cutting equipment produces fumes or gases which contain chemicals known in the State of California to cause birth defects and, in some cases, cancer. (California Health & Safety Code Section 25249.5 et seq.)



WARNING!

This product can expose you to chemicals including lead, which are known to the state of California to cause cancer and birth defects or other reproductive harm. Wash hands after use.

For more information, go to www.P65Warnings.ca.gov.

2 INTRODUCTION

The **Sentinel A-60** is an auto-darkening welding helmet intended for use in most welding processes.

ESAB has an assortment of welding accessories and personal protection equipment for purchase. For ordering information contact your local ESAB dealer or visit us on our website.

2.1 Certification and control labels

The SENTINEL™ A-60 conforms to PPE Regulation 2016/425/EU, Regulations (EU) 2016 as brought into UK law and amended and harmonized/designated standard EN 166:2001, EN 175:1997 and EN379:2003+A1:2009. Approved body for UK certification: SGS United Kingdom Limited, Rossmore Business Park, Ellesmere Port South Wirral Cheshire, CH65 3EN notified body no. 0120. Notified body for CE Certification: ECS GmbH, Huettfeldstrasse 50 / Obere Bahnstrasse 74, 73430 AALEN / 73431 AALEN GERMANY that provides approval and continual quality system under the control of the European Commission, the German Ministry for Work and the Central Office of the Provinces. The shell and the auto darkening filter are marked accordingly. Classification for eye and face protection is following EN379, EN175, EN166.

We are therefore allowed to use the following marks:



EN 175

EN 166

EN 379

European Conformity mark

ADF marking explanation

3/5-9/9-13 ESAB 1/1/1/1/379 CE UKCA

3	Light state scale number
5-9 /9-13	Dark state scale number
ESAB	Manufacturer's name
1	Optical class
1	Diffusion of light class
1	Variation in luminous transmittance class
1	Angle dependence of luminous transmittance class
379	Number of the standard

16321 ESAB W3/5-9/9-13 V1

16321	Number of the ISO standard
ESAB	Manufacturer's name
3	Light state scale number
5-9 /9-13	Dark state scale number
V1	Angle dependence of luminous transmittance class

Welding helmet marking explanation

ESAB EN175 B CE UKCA

ESAB	Manufacturer's name
EN175	Testing standard

B	Resistance against medium energy impact (120 m/s)
CE	European conformity
UKCA	UK conformity

Front/inside cover lens explanation

ESAB 1 B CE UKCA

ESAB	Manufacturer's name
1	Optical class
B	Resistance against medium energy impact (120 m/s)
CE	European conformity
UKCA	UK conformity

3 TECHNICAL DATA

Weight	644 gm (1.42 lbs)
Optical class	1 / 1 / 1 / 1
ADF dimension (l × h)	132 × 121 mm (5.20" × 4.76")
Viewing area	118 × 71 mm (4.65" × 2.8")
Arc sensor	4
Light state	DIN 3
Grind state	DIN 3
Welding mode	Shade no. from 5-8/9-13
Shade control	Internal, variable shade, digital button control
Power On/Off	Automatic On/Off
Sensitivity control	Low — high, digital button control
UV/IR protection	Up to shade DIN 16 at all times
Power supply	Solar cell and replaceable 2 × CR2450 lithium battery
Switching time	1/25,000 s. from light to dark
Grinding mode	Yes, via external push button or internal mode selection
Delay (dark to light)	0.1 ~ 0.9 s digital button control
Low amperage TIG rated	≥ 3 amps
Operating temperature	-10 °C to 65 °C (14 °F to 149 °F)
Storage temperature	-20 °C to 85°C (-4 °F to 185 °F)
Certifications	CE (EN166 ; EN175 ; EN379), ISO 16321 V1 +TIG, UKCA ANSI Z87.1, CSA Z94.3, AS/NZS 1338.1

3.1 Shade guide

Shade numbers

Operation	Electrode size 1/32 in. (mm)	Arc current (A)	Minimum protective shade	Suggested ⁽¹⁾ shade no. (comfort)
Shielded metal arc welding	Less than 3 (2.5)	Less than 60	7	—
	3-5 (2.5–4)	60-160	8	10
	5-8 (4–6.4)	160-250	10	12
	More than 8 (6.4)	250-550	11	14
Gas metal arc welding and flux Cored arc welding		Less than 60	7	—
		60-160	10	11
		160-250	10	12
		250-500	10	14

Operation	Electrode size 1/32 in. (mm)	Arc current (A)	Minimum protective shade	Suggested ⁽¹⁾ shade no. (comfort)
Gas tungsten arc welding		Less than 50	8	10
		50-150	8	12
		150-500	10	14
Air carbon Arc cutting	(Light)	Less than 500	10	12
	(Heavy)		11	14
Plasma arc welding		Less than 20	6	6 to 8
		20-100	8	10
		100-400	10	12
		400-800	11	14
Plasma arc cutting	(Light) ⁽²⁾	Less than 300	8	8
	(Medium) ⁽²⁾	300-400	9	12
	(Heavy) ⁽²⁾		10	14
Torch brazing		–	–	3 to 4
Torch soldering		–	–	2
Carbon arc welding		–	–	14

Plate thickness

Operation	in.	mm	Suggested ⁽¹⁾ shade no. (comfort)
Gas welding	Under 1/8	Under 3.2	4 or 5
	Light 1/8 to 1/2	3.2 to 12.7	5 or 6
	Medium Over 1/2	Over 12.7	6 or 8
	Heavy		
Oxygen cutting	Under 1	Under 25	3 or 4
	Light 1 to 6	25 to 150	4 or 5
	Medium Over 6	Over 150	5 or 6
	Heavy		

⁽¹⁾ As a rule of thumb, start with a shade that is too dark, then go to a lighter shade which gives a sufficient view of the weld zone without going below the minimum. In oxyfuel gas welding or cutting where the torch produces a high yellow light, it is desirable to use a filter lens that absorbs the yellow or sodium line the visible light of the (spectrum) operation.

⁽²⁾ These values apply where the actual arc is seen. Experience has shown that lighter filters may be used when the arc is hidden by the workpiece.

Data from ANSI Z49.1-2005

4 INSTALLATION

4.1 Installing the battery



WARNING!

Keep the battery away from children!

- 1) Use the included screwdriver, or other similar-sized screwdriver to remove the retention screw.



- 2) Slide the battery cover out of the external control case and install the battery properly (“+ side facing UP”), slide the cover back into position after battery installation.



- 3) Insert the screw and tighten.

4.2 Installing magnifying lens

- 1) Install the magnifying lens into the magnifying lens frame.
- 2) Install the magnifying lens frame into the Auto-Darkening filter by sliding it down into the magnifier frame retention bracket.

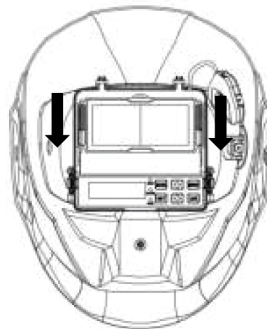

4.3 Adjusting the fit of the helmet

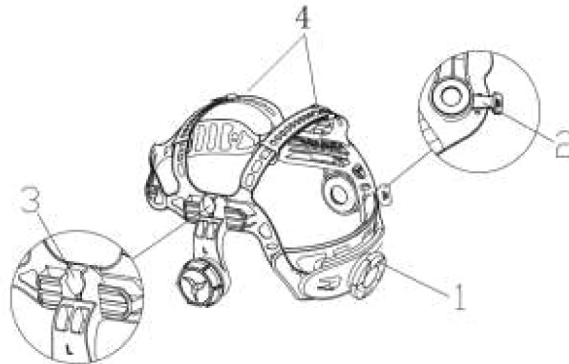

Adjusting the circumference of the headband

- 1) Rotate the knob (1) on the back of the headband to make the overall circumference of the headband larger or smaller.

This can be done while wearing the helmet and allows easy micro-level tension adjustment to keep the helmet firmly on the head without it being too tight.

- 2) If the headband is riding too high or too low on your head, adjust the straps (4) which passes over the top of your head.
 - a) Release the end of the band by pushing the locking pin out of the band's hole.
 - b) Slide the two portions of the band to a greater or lesser width as required.
 - c) Push the locking pin through the nearest hole.

Adjusting view angle position

- 1) The tilt adjustment is located on the right side of the helmet. Loosen the right headgear tension knob (2) and adjust the lever forward or back to the desired position.
- 2) Retighten the right headgear tension knob.

Adjusting the distance between the ADF and face

- 1) Press and hold the slider (3) on both sides, to slide the headgear back and forth within the helmet.
- 2) Ensure the slider is locked back into position and make certain the distance between the lens to both eyes is equal. This avoids issues with uneven ADF darkness.

5 OPERATION

General safety regulations for handling the equipment can be found in the "SAFETY" chapter of this manual. Read it through before you start using the equipment!

5.1 Activating the LED display

- 1) Press any button on the Auto-Darken filter (ADF) control panel or press the external "Grind" button.



The LED display automatically turns off after 10 seconds if no buttons are pressed. Symbols on the LED display flash during adjustment and stop flashing after 8 seconds if there is no adjustment. The current settings will remain active.

5.2 Battery indicator

The auto-darkening filter is powered by a solar cell and two CR2450 lithium batteries.

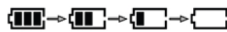
The  symbol shows the current state of the battery and identifies four levels of current capacity:



Replace the battery with a new one when the indicator symbol shows  and the  red LED is continuously illuminated.

5.3 Activating grind mode



WARNING!

Do not weld while using grind mode!

Option 1

- 1) Press the  button on the ADF to switch to grind mode.



Option 2

- 1) Press the "GRIND" button on the upper right external side of the helmet shell for 2 seconds. ADF switches to grind mode.
- 2) Press the "GRIND" button for 2 seconds again, and it returns to the previous welding shade setting.





During grind mode, the lens shade is fixed shade 3 and cannot be adjusted. Grind indicator is an amber LED on the ADF control panel, and flashes when grind mode is active.

5.4 Setting shade number

- 1) Press the  button on the ADF control panel. This switches the shade mode between shade banks 5-9, 9-13, or Grind. Select the shade range between shade 5-9 or shade 9-13.
- 2) Press the "SET" button to select the shade. Press  to increase the shade number, and press  to reduce the shade number. Select the proper shade number for your welding or cutting process by referring to the Shade guide.

5.5 Setting sensitivity

Sensitivity can be adjusted only while using the welding mode.

- 1) Select desired shade.
- 2) Press the "SET" button to select sensitivity. The **SENSI.** symbol flashes. Press  to increase the sensitivity, and press  to reduce the sensitivity.

This allows the ADF to become more or less sensitive to arc light, for different welding processes.



 **SENSI.** indicates sensitivity is at low. Low sensitivity is suitable for using outdoors (excessive ambient/environmental light conditions) and with higher amperage SMAW and FCAW operations.

 **SENSI.** indicates sensitivity is at high. High sensitivity is suitable for low amperage welding with GTAW or GMAW operations.

Under normal welding conditions, a higher sensitivity setting is recommended.

5.6 Setting delay

Delay can be adjusted only while using the welding mode.

- 1) Select desired shade.
- 2) Press the "SET" button to select delay. The **DELAY** symbol flashes. Press  to increase the delay, and press  to reduce the delay.





This setting adjusts the amount of time the lens takes to lighten after welding. There are 5 settings to adjust delay, with a delay range of 0.1~0.9 seconds.

 **DELAY** Indicates the longest delay setting. The longest time is about 0.9 seconds depending upon welding point temperature and shade set. This setting is ideal for welding at high amperage where there is an afterglow from the weld.

 **DELAY** indicates the shortest delay setting. The shortest time is about 0.1 second depending upon welding point temperature and shade set. This setting is ideal for tack welding or production welding with short welds.



5.7 Saving parameters to memory settings

It's possible to save the setting parameters into a memory setting. Users can recall a memory at any time they need. The system can save up to 9 sets of parameters. Take memory setting 1 as an example:

- 1) Press the  button on the ADF control panel, select memory set to position "1" by pressing  or ; the memory number symbol  flashes.
- 2) Set shade, sensitivity, and delay according to instructions.
- 3) After finishing all settings, the ADF stores the parameters automatically after 10 seconds if there is no operation. The memory position will be position "1".
- 4) MEMORY 2 to MEMORY 9 can be set the same way. Users can call out the MEMORY setting by selecting the memory position via short press "MEMORY" first and then choosing the desired memory number. The ADF changes to the selected setting from memory automatically after 10 seconds.

5.8 Activating lock shade mode

The lock shade mode allows the ADF to remain activated to the chosen welding shade setting while it is in lock mode. The ADF will not return to a light state.

- 1) Press the  button and hold for 2 seconds, the ADF changes to lock shade mode.
- 2) Select the shade number from 5-13.
- 3) Press the  button and hold for 2 seconds, the ADF reverts to standard operating mode.

6 MAINTENANCE



CAUTION!

Repair and electrical work should be performed by an authorised ESAB service technician. Use only ESAB original spare and wear parts.



NOTE!

Regular maintenance is important for safe and reliable operation.

ESAB recommends a use period of five years. The duration of use depends on various factors such as use, cleaning, storage and maintenance.

Before each use:

- Carefully inspect the auto-darkening welding helmet for worn or damaged parts.
- Replace any worn or damaged parts.

6.1 Replacing the front cover lens

Replace the front cover lens if it becomes scratched or damaged.



NOTE!

Avoid placing the helmet face down when not in use. This helps lengthen the lifespan of the front cover lens.

- 1) Press the semicircle lens retention button on the external side adjacent to the external grind mode button (right side as worn), and remove the front cover lens carefully.

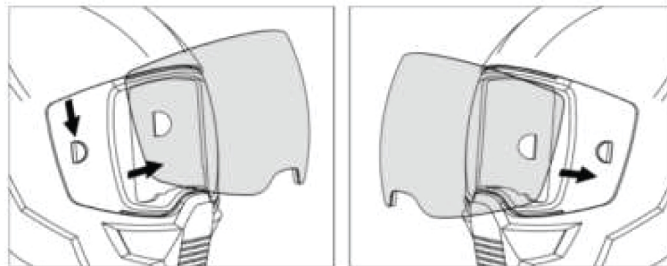

- 2) When replacing with a new front cover lens, make sure to assemble from the side opposite first, and then snap the lens into the lens retention button side.

6.2 Replacing the inside cover lens

Replace the inside cover lens if it is damaged.

- 1) Lift the lens at the recess below the Auto-Darkening filter.

The inside cover lens will flex upward and release from the cartridge.

6.3 Replacing the Auto-Darkening-Filter (ADF)

- 1) Remove the external Grind button's retainer screw, located on the right-side edge of the battery compartment inside the helmet shell and behind the Grind button.
- 2) Push the locks on both sides of the ADF, push the Grind button inward by pressing it firmly, then the ADF can be removed from the shell.
- 3) When installing a new ADF, install the Grind button from inside the shell, press it firmly then put the ADF into the shell and lock the Auto-Darkening filter into place.

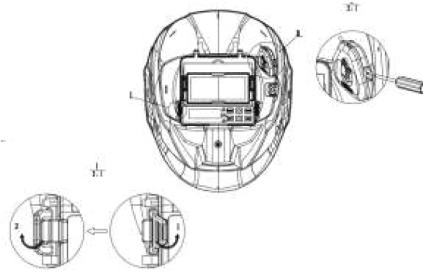

6.4 Cleaning the equipment



NOTE!

Do not use strong cleaning solutions.

- 1) Clean helmet by wiping with a soft, dry cloth.
- 2) Clean the cartridge surfaces regularly.

7 TROUBLESHOOTING

Perform these checks and inspections before sending for an authorised service technician.

Type of fault	Possible cause	Corrective action
Irregular darkening or dimming	Headgear is set incorrectly	Check to ensure the fore/aft adjustment to the headgear is set to the same position on both sides of the headgear. This ensures the correct and equal distance of the ADF to the user's eyes.
The ADF does not darken or flicker	The front cover lens is soiled or damaged	Change the cover lens
	Sensors are soiled	Clean the surface of the sensor
	Welding current is too low	Adjust the sensitivity level higher
	Battery fail	Check battery and verify they are in good condition and installed properly. Also, check battery surfaces and contacts and clean if necessary.
Slow response	The operating temperature is too low	Do not use at temperatures below -5 °C or 23 °F)
Poor vision	Front / inside cover lens and/or the filter is soiled	Change lens
	Insufficient ambient light	Increase light
	Shade number is incorrectly set	Reset the shade number
	Protective film has not been removed	Ensure the protective film has been removed from the outer cover lens before first use
Welding helmet slips	Headgear is not properly adjusted	Readjust the headgear
	Headgear is damaged	Replace the headgear

APPENDIX

SPARE PARTS

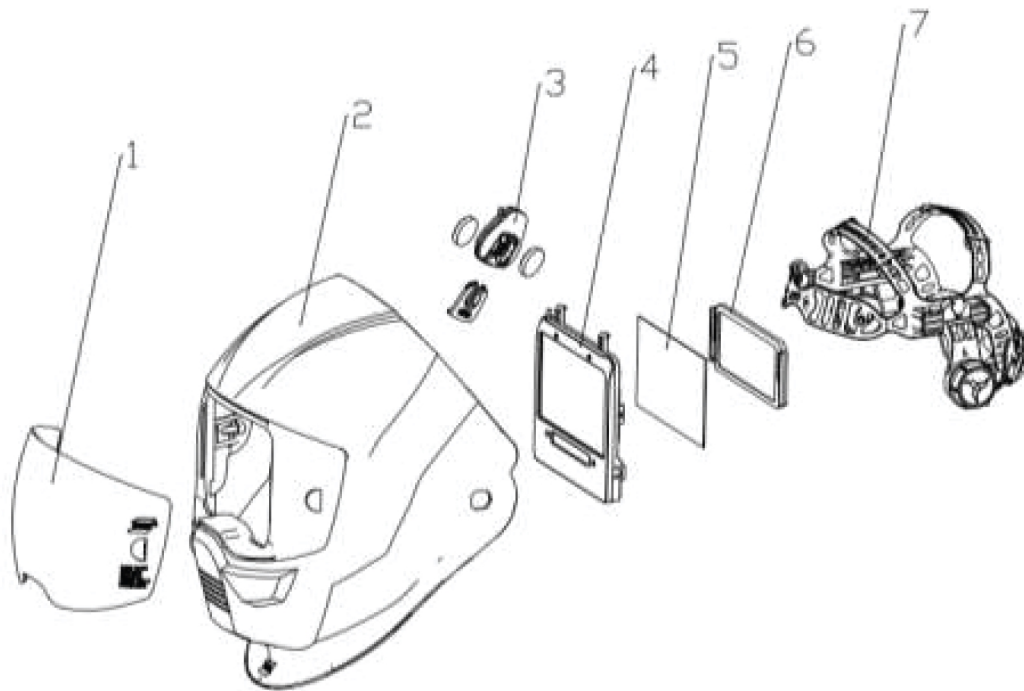

Item	Ordering no.	Denomination
1	0700 600 880	A-60 Front Cover Lens Clear
	0700 600 881	A-60 Front Cover Lens Amber
	0700 600 882	A-60 Front Cover Lens Clear HD
	0700 600 883	A-60 Front Cover Lens Amber HD
2	0700 600 863	Sentinel A-60 Helmet Shell
	0700 600 864	Sentinel A-60 Air shell with air duct
3	Reference	Batteries 2*CR2450
4	0700 600 865	Auto-Darkening Filter (excl. batteries)
5	0700 600 866	Inside Cover Lens (121.5 x 74.5mm)
6	N/A	Magnifying Lens Frame (Provided with Magnifying Glass)
7	0700 600 867	Headgear Assembly for A-60 (Including sweatbands)
	0700 600 868	Headgear Assembly for A-60 Air (including sweatbands)
	0700 600 869	Front Sweat Band (forehead) with ESAB Logo
	0700 600 872	Magnifying Glass +1.0 Diopter (For A-60 Air)
	0700 600 873	Magnifying Glass +1.5 Diopter (For A-60 Air)
	0700 600 874	Magnifying Glass +2.0 Diopter (For A-60 Air)
	0700 600 875	Magnifying Glass +2.5 Diopter (For A-60 Air)



A WORLD OF PRODUCTS AND SOLUTIONS.



ESAB AB
Lindholmsallén 9
Box 8004
402 77 Gothenburg
Sweden
Phone +46 (0) 31 50 90 00

ESAB Corporation
2800 Airport Road
Denton, TX 76207
USA
Phone +1 800 378 8123

ESAB Holdings Ltd
322 High Holborn
WC1V 7PB
London, Great Britain
Phone +44 (0) 1992 768515

For contact information visit esab.com

manuals.esab.com

